

Fresa circular, corte 3 lados, dentes cruzados e alternados.
 Side milling cutter, cutting on 3 sides, staggered teeth.

DENTES CRUZADOS
HÉLICE 30°
M2
DIN 885 AW

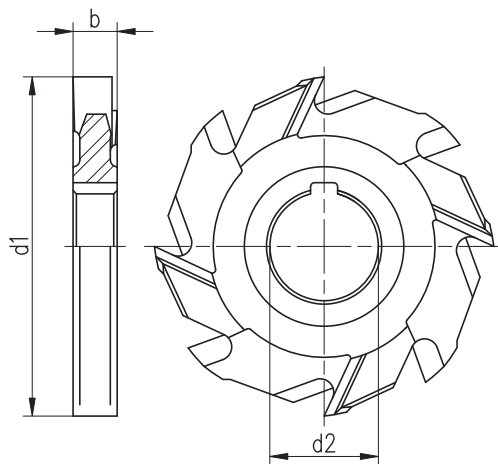

1214



d1 js 16 mm	b k 11 mm	d2 H7 mm	Z
50	4	16	6
50	5	16	6
50	6	16	6
50	8	16	6
50	10	16	6
63	4	22	6
63	5	22	6
63	6	22	6
63	8	22	6
63	10	22	6
63	12	22	6
63	14	22	6
63	16	22	6
63	18	22	6
80	5	27	6
80	6	27	6
80	8	27	6
80	10	27	6
80	12	27	6
80	14	27	6
80	16	27	6
80	18	27	6
80	20	27	6
100	6	32	8
100	8	32	8
100	10	32	8
100	12	32	8
100	14	32	8
100	16	32	8
100	18	32	8
100	20	32	8
100	22	32	8
100	25	32	8

d1 js 16 mm	b k 11 mm	d2 H7 mm	Z
125	6	32	8
125	8	32	8
125	10	32	8
125	12	32	8
125	14	32	8
125	16	32	8
125	18	32	8
125	20	32	8
125	22	32	8
125	25	32	8
125	28	32	8
150	6	32	10
150	8	32	10
150	10	32	10
150	12	32	10
150	14	32	10
150	16	32	10
150	18	32	10
150	20	32	10
150	22	32	10
150	24	32	10
150	26	32	10
150	28	32	10
160	8	40	10
160	10	40	10
160	12	40	10
160	14	40	10
160	16	40	10
160	18	40	10
160	20	40	10
160	22	40	10
160	25	40	10
160	28	40	10
160	32	40	10
200	8	40	12
200	10	40	12
200	12	40	12
200	14	40	12
200	16	40	12
200	18	40	12
200	20	40	12
200	22	40	12
200	25	40	12
200	28	40	12
200	32	40	12
200	36	40	12
200	40	40	12
250	10	40	14
250	12	40	14
250	14	40	14
250	16	40	14
250	18	40	14
250	20	40	14
250	25	40	14
250	28	40	14
250	32	40	14