

Fresa circular, corte 3 lados, dentes cruzados e alternados.
Side milling cutter, cutting on 3 sides, staggered teeth.

DENTES CRUZADOS	HÉLICE 12°/15°	M2	DIN 885 AN		
--------------------	-------------------	----	---------------	--	--

1211

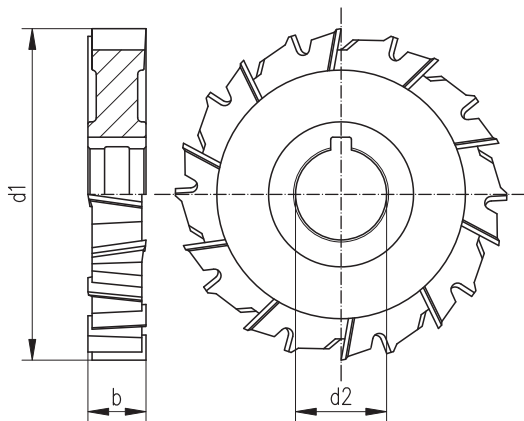
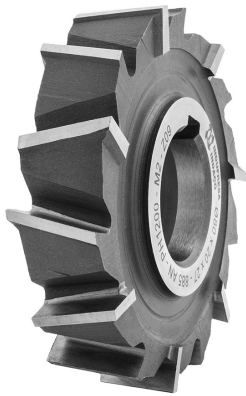

d1 js 16 mm	b k 11 mm	d2 H7 mm	Z
50	4	16	10
50	5	16	10
50	6	16	10
50	8	16	10
50	10	16	10
63	4	22	12
63	5	22	12
63	6	22	12
63	8	22	12
63	10	22	12
63	12	22	12
63	14	22	12
63	16	22	12
63	18	22	12
80	5	27	14
80	6	27	14
80	8	27	14
80	10	27	14
80	12	27	14
80	14	27	14
80	16	27	14
80	18	27	14
80	20	27	14
100	6	32	16
100	8	32	16
100	10	32	16
100	12	32	16
100	14	32	16
100	16	32	16
100	18	32	16
100	20	32	16
100	22	32	16
100	25	32	16
125	6	32	16
125	8	32	16
125	10	32	16
125	12	32	16
125	14	32	16
125	16	32	16
125	18	32	16
125	20	32	16
125	22	32	16
125	25	32	16
125	28	32	16

d1 js 16 mm	b k 11 mm	d2 H7 mm	Z
150	6	32	18
150	8	32	18
150	10	32	18
150	12	32	18
150	14	32	18
150	16	32	18
150	18	32	18
150	20	32	18
150	22	32	18
150	24	32	18
150	26	32	18
150	28	32	18
160	8	40	18
160	10	40	18
160	12	40	18
160	14	40	18
160	16	40	18
160	18	40	18
160	20	40	18
160	22	40	18
160	25	40	18
160	28	40	18
160	32	40	18
200	8	40	22
200	10	40	22
200	12	40	22
200	14	40	22
200	16	40	22
200	18	40	22
200	20	40	22
200	22	40	22
200	25	40	22
200	28	40	22
200	32	40	22
200	40	40	22
250	10	40	32
250	12	40	32
250	14	40	32
250	16	40	32
250	18	40	32
250	20	40	32
250	25	40	32
250	28	40	32
250	32	40	32

NOTA:
Ângulo de hélice 12° até diâmetro de 100mm
Ângulo de hélice 15° a partir de 125mm